

A.224

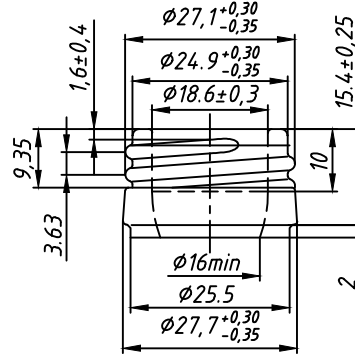
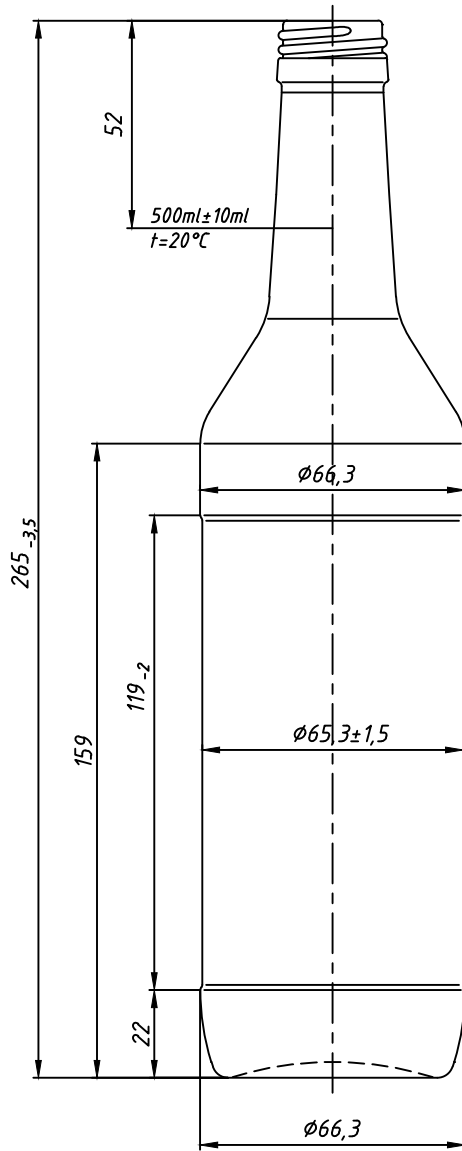

The controllable sizes of a glass finish

- Ø27.1 ^{+0.30}/_{-0.35}
- Ø27.7 ^{+0.30}/_{-0.35}
- Ø18.6 ± 0.3 should be on depth 10 mm from a finish end face
- Ø16 min in other part of a mouth
- Finish type B-28-1
- GOST 10117.2-2001

The signature and date	<p>Characteristics</p> <p>Nominal capacity, cm³ -500</p> <p>Full capacity, cm³ 500⁺¹⁰/₋₅</p> <p>Weight recommended, g - 307</p>		<p>The packing scheme of the bottles in the pallet</p>		<p>Quantity of layers: 8</p> <p>Quantity of bottles in the pallet: 2384</p> <p>Weight of the pallet, kg: 782</p> <p>Roof: a cardboard</p> <p>Cover: thermocontractable</p>																											
Instead of accession N Duplicate accession N	<p>SM 195:1999 ; GOST 10117.1</p> <p>Thickness of walls, mm-1.4, at application of hardening, not less-1 mm</p> <p>Thickness of a bottom, mm-2.5, at application of hardening, not less, -2.2 mm</p> <p>Thermal stability, difference of temperatures, not less, °C -35</p> <p>Internal hydrostatic pressure during 60±2s not less, kgf/cm²-5</p>																															
The signature and date	<p>Maximum deviation</p> <p>from a vertical axis not more, mm 3.7</p> <p>for height, mm 3.5</p> <p>for diameter of the body, mm ±1.5</p> <p>Nominal capacity in terms of filling, cm³ - ⁺¹⁰/₋₅</p> <p>other sizes are given for manufacturing set of forms</p>		<p>A.224</p>		<table border="1"> <thead> <tr> <th>Letter</th> <th>Weight</th> <th>Scale</th> </tr> </thead> <tbody> <tr> <td></td> <td></td> <td>1:1.25</td> </tr> </tbody> </table>		Letter	Weight	Scale			1:1.25																				
Letter	Weight	Scale																														
		1:1.25																														
Original accession N	<p>Agreed:</p>		<table border="1"> <thead> <tr> <th>Change</th> <th>Letter</th> <th>Document N</th> <th>Signature</th> <th>Date</th> </tr> </thead> <tbody> <tr> <td>Designed</td> <td></td> <td>Djalo A. I.</td> <td></td> <td>02.04.18</td> </tr> <tr> <td>Constr-r principal</td> <td></td> <td>Djalo A. I.</td> <td></td> <td>02.04.18</td> </tr> <tr> <td>Dir. of manuf.</td> <td></td> <td>Rotari N.V.</td> <td></td> <td></td> </tr> </tbody> </table>		Change	Letter	Document N	Signature	Date	Designed		Djalo A. I.		02.04.18	Constr-r principal		Djalo A. I.		02.04.18	Dir. of manuf.		Rotari N.V.			<table border="1"> <thead> <tr> <th>Sheet</th> <th>Sheets</th> <th>1</th> </tr> </thead> <tbody> <tr> <td colspan="2" style="text-align: center;">FSC</td> <td style="text-align: center;"></td> </tr> </tbody> </table>		Sheet	Sheets	1	FSC		
Change	Letter	Document N	Signature	Date																												
Designed		Djalo A. I.		02.04.18																												
Constr-r principal		Djalo A. I.		02.04.18																												
Dir. of manuf.		Rotari N.V.																														
Sheet	Sheets	1																														
FSC																																